

WOODHAVEN

BEFORE BEGINNING

Identify and verify that you have all the parts listed. Read the instructions at least once, familiarizing yourself with the parts and assembly instructions before beginning. You'll need a #3 Phillips screwdriver and a 7/16" wrench for assembly.

ASSEMBLY

Insert a 1" screw (**MF015**) thru the four countersunk holes in the drill press table (**1826A**), place the table upside down on a flat surface and start an oval nut (**5760B - raised side first**) on the end of the screws. Slide a 8" Ultra Track (**4408**) on two oval nuts until it's centered end-to-end on the oval nuts and the face of the Ultra Track is flush with the edge of the drill insert (**1826B**) opening, then tighten the screws. *See fig. 1 & upper inset photo.*

Install two 1" washers (**WFN002**) on each 3/4" bolt (**HB020**), insert the bolts thru the holes in the leveler (**1826D**) and start an oval nut (**5760B - raised side first**) on the bolt ends.

1826 Drill Press Table

Please Read Carefully!

Parts List:

Part	Description	Quantity
1826A	Drill Press Table	1
1826B	Drill Insert	1
1826C	Square Washer	4
1826D	Leveler.	2
4408	8" Ultra Track	2
NUT015	Nut.	4
HB050	1-1/2" Bolt.	4
HB020	3/4" Bolt	4
MF015	1" Screw	4
WFN002	1" Washer	12
5760B	Oval Nut.	8
WL001	Lock washer.	4

Install the levelers on the Ultra Track by inserting the oval nuts into the T-slot of the track. Position the levelers over the drill insert, with the edge of the levelers resting against the underside of the drill insert, tighten the bolts. *See fig. 1 & lower inset.*

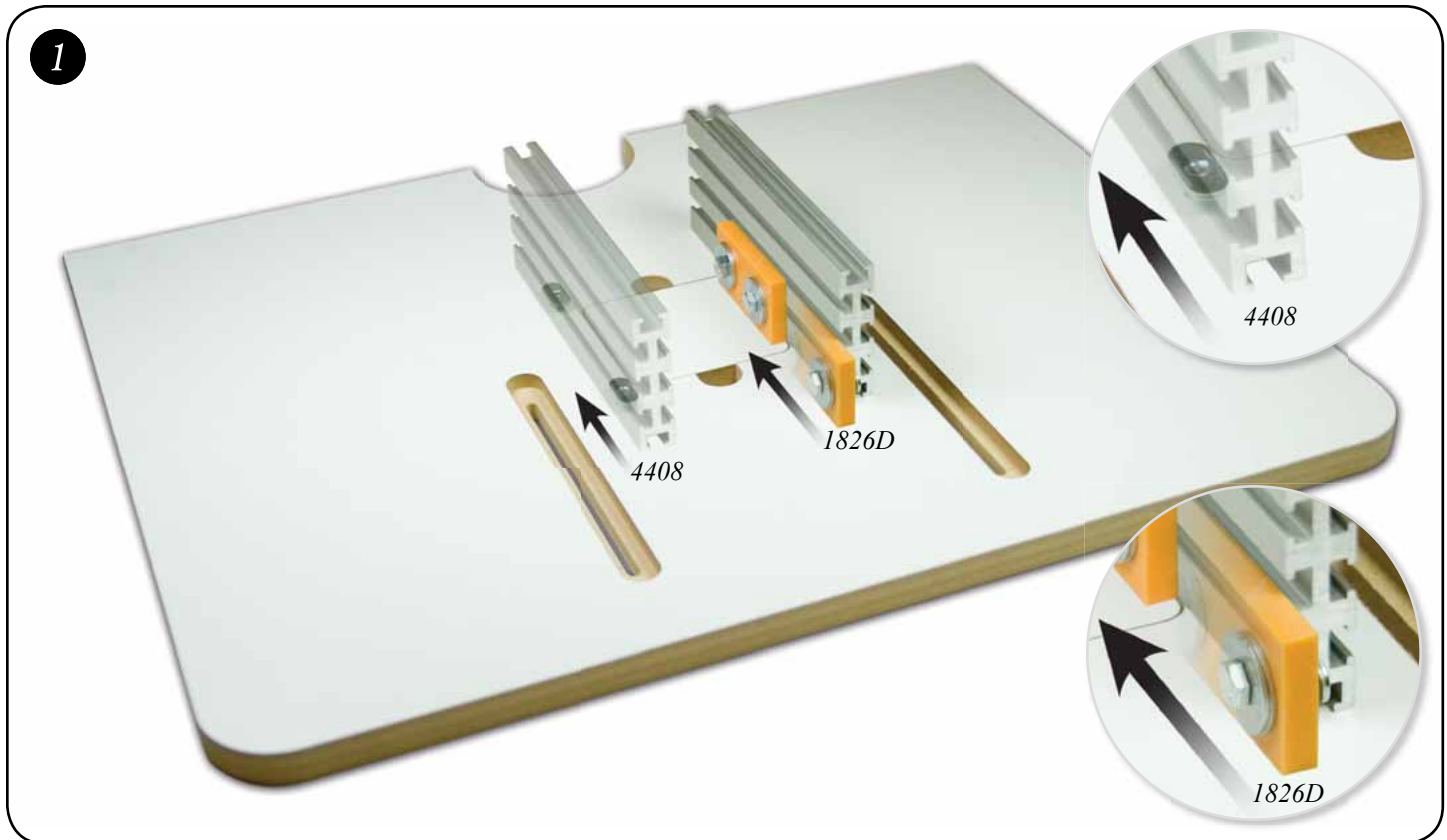

On each of the 1-1/2" bolts (**HB050**), install a square washer (**1826C**), a 1" washer (**WFN002**), a lock washer (**WL001**) and a nut (**NUT015**). Insert the head of two bolts (one at a time) up thru the front two slots in your drill press table and slide the Ultra Tracks connected to the Woodhaven drill press table on to the bolt heads. Repeat for the back two slots.

Note: If the bolt heads won't fit thru the slots in your drill press table, you will have to assemble the hardware on the bolt after you've inserted the bolt thru the slot. Adjust the Woodhaven drill press table so it's centered left-to-right and front-to-back (or where desired) on your drill press and tighten the nuts. *See fig. 2.*

ACCESSORIES

The Drill Press Fence (**1827 or 1827XL**) and Flip Stops (**4512 or 4514**) increase your speed and efficiency when drilling multiple parts.

The Toggle Clamp Kit (**1826T**) provides 500 lbs. of clamping force and the Drill Press Table has two slots for up to two of these clamps to be used. *See fig. at right*

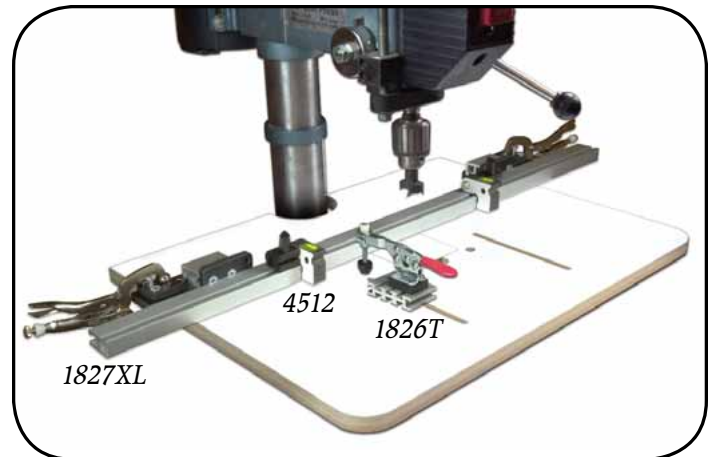

©Copyright WOODHAVEN INC. 9/7/07
(800) 344-6657 or WWW.WOODHAVEN.COM

